

BIFENIX®

NOVA

Quick Installation Guide

Contents

- **Nova Quick Installation Guide**

- Accessory:
- ⊕ 10x Mainboard screws (6-32)
- ⊕ 3x Mainboard standoffs (6 standoffs are embedded on the Mainboard tray)
- ⊕ 16x 3.5" HDD screws
- ⊕ 4x 2.5" HDD/SSD screws
- ⊕ 3x Front-Panel screws
- ⊕ 1x Speaker

Overview

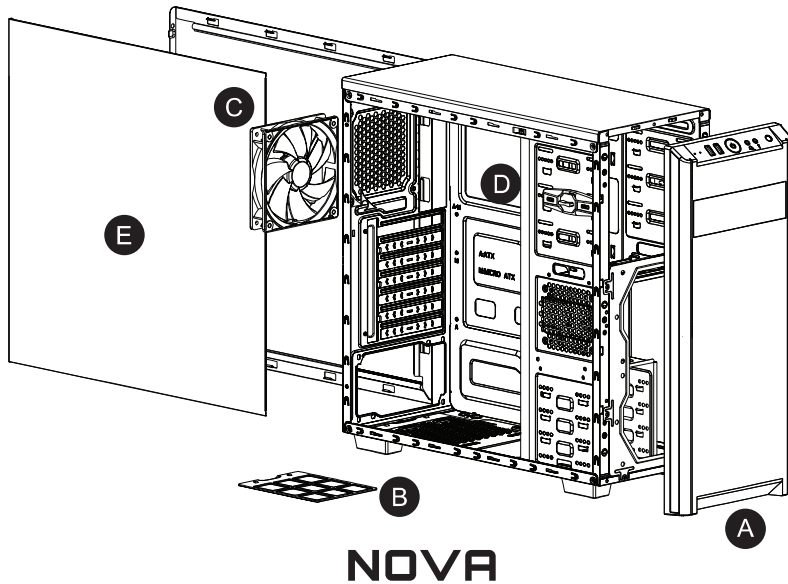

- A** Front Panel
- B** Dust Filter
- C** Fan (120mm)
- D** ODD clip
- E** Side Panel
- F** Windos Panel

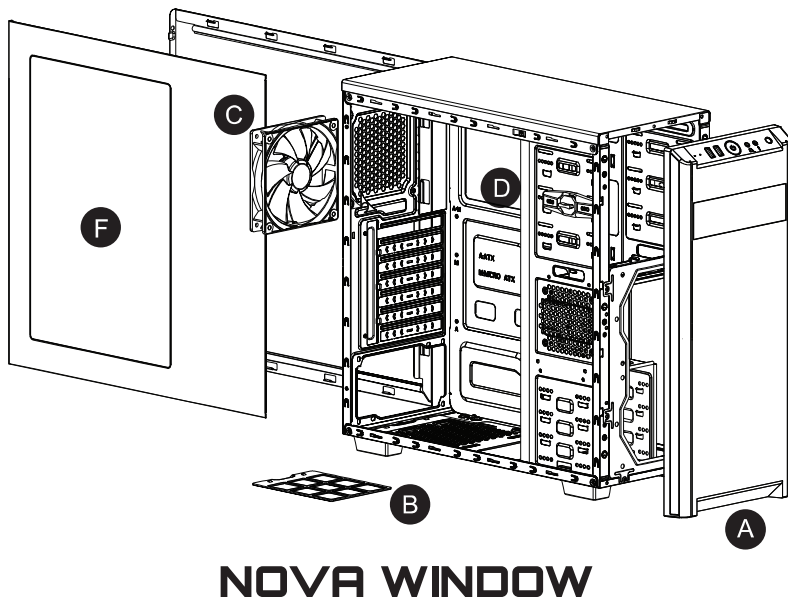

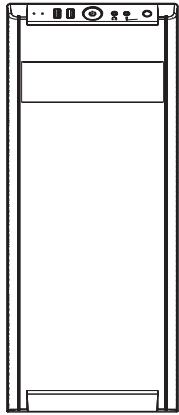

Front

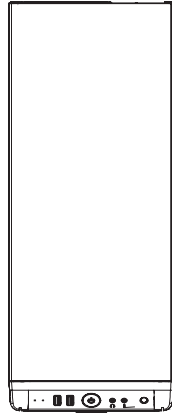

Top

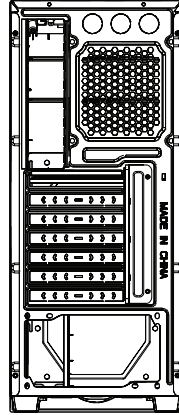

Back

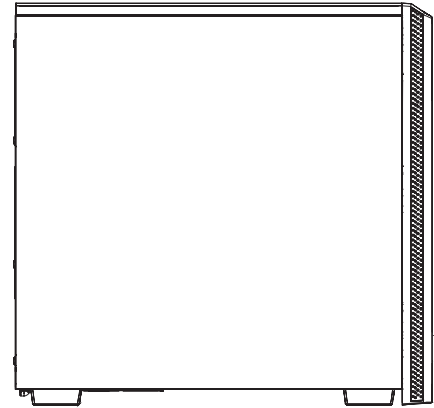

Left Side

Basic Installation

How to remove the side panels

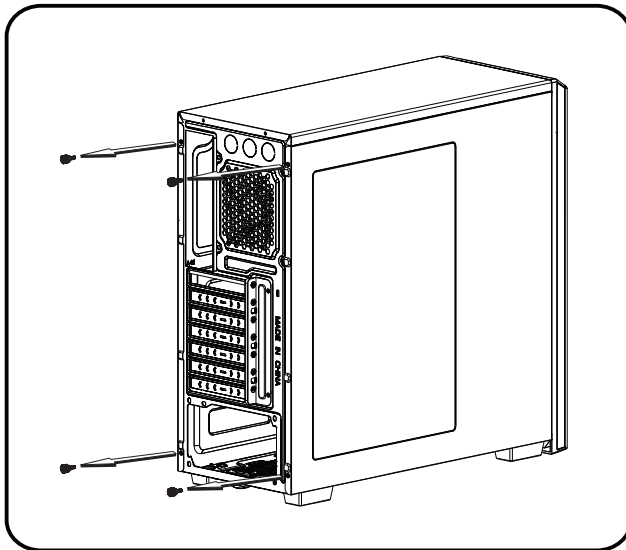

a. Remove thumbscrews

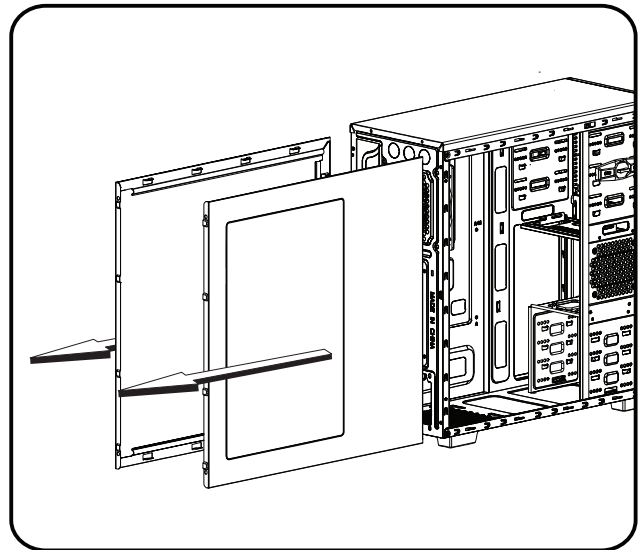

b. Slide the side panels towards the back of the case

How to remove/clean the PSU dust filters

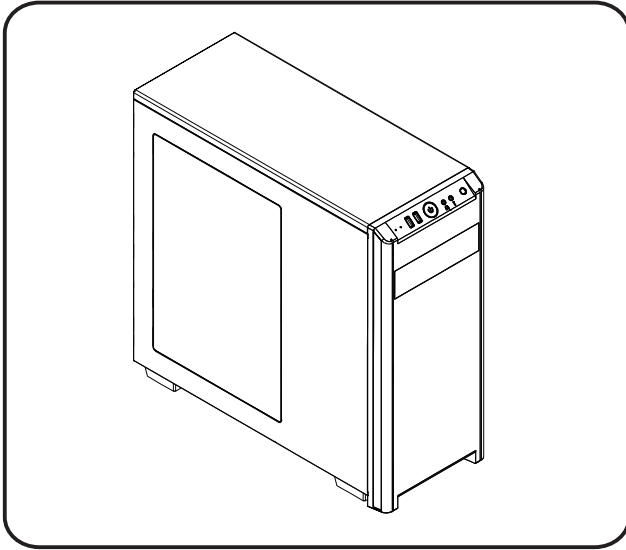

FRONT

Remove front panel

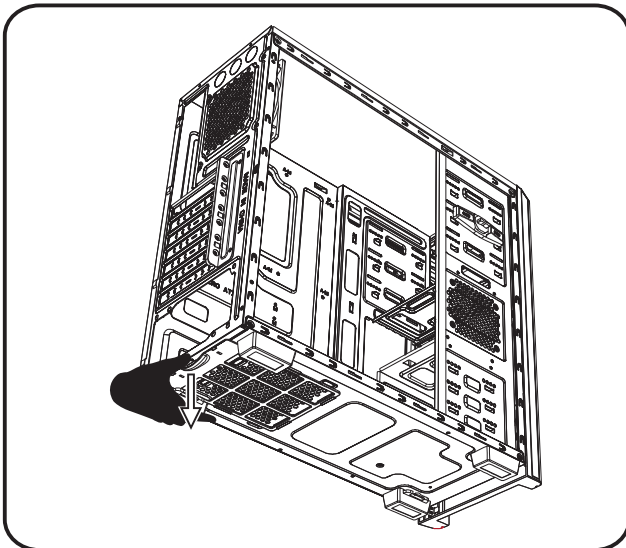
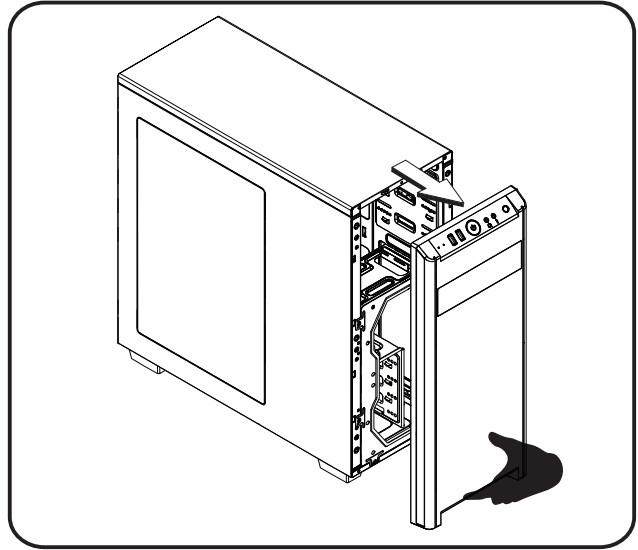

BOTTOM

Pull the PSU dust filter away from the case to remove it

Installing 3.5" Drives

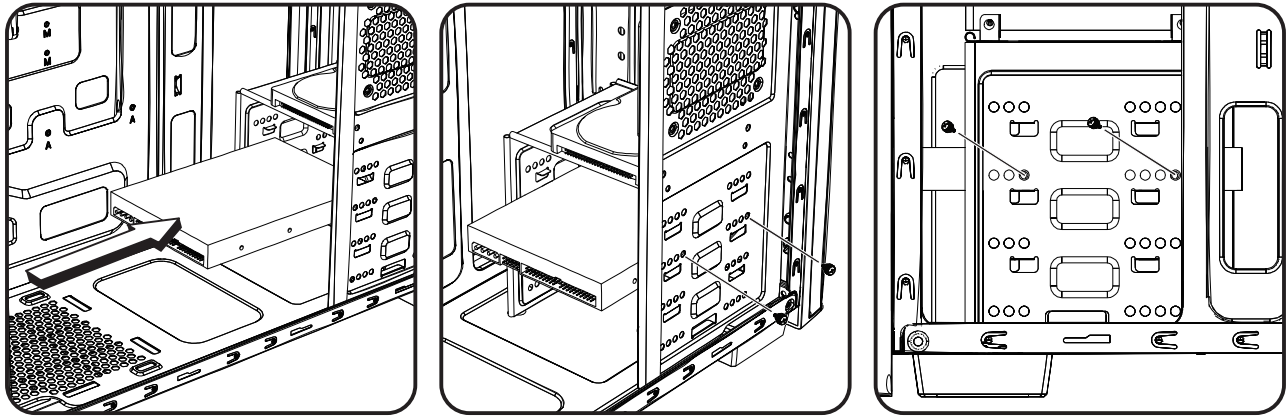

- a. Slide drive into drive bay b. Secure with screws (for extra support, remove right sidepanel and install screws on the right side as well)

Installing 2.5" Drives

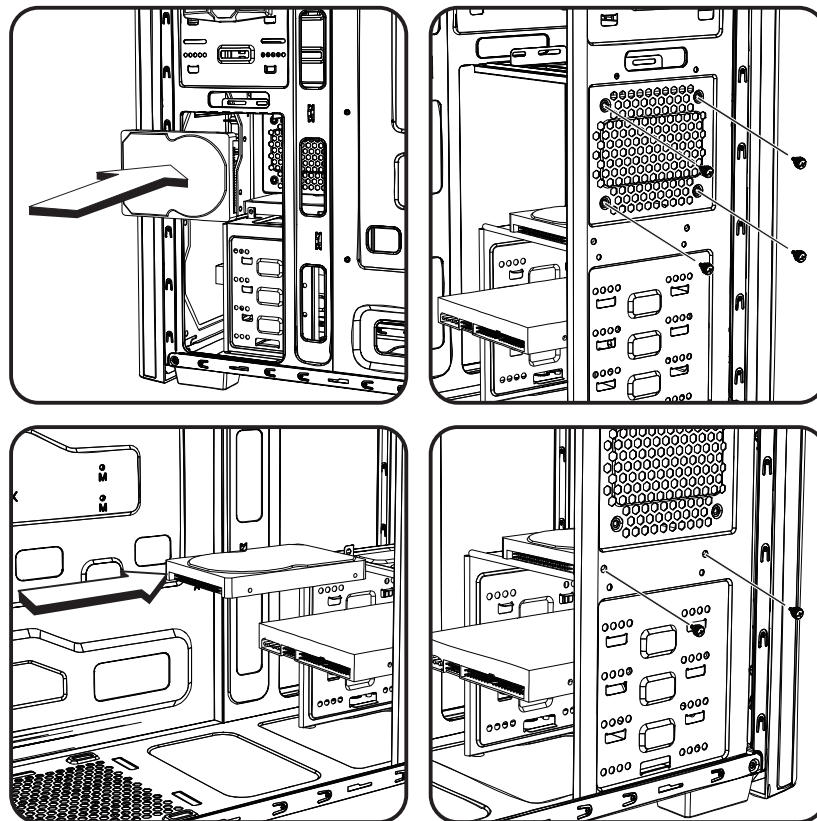

- a. Slide drive into drive bay
b. Secure with screws (for extra support, remove right sidepanel and install screws on the right side as well)

Front Fan Installation

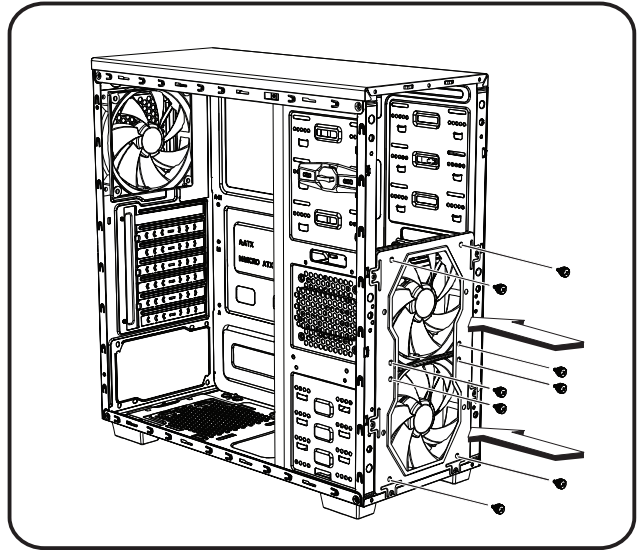
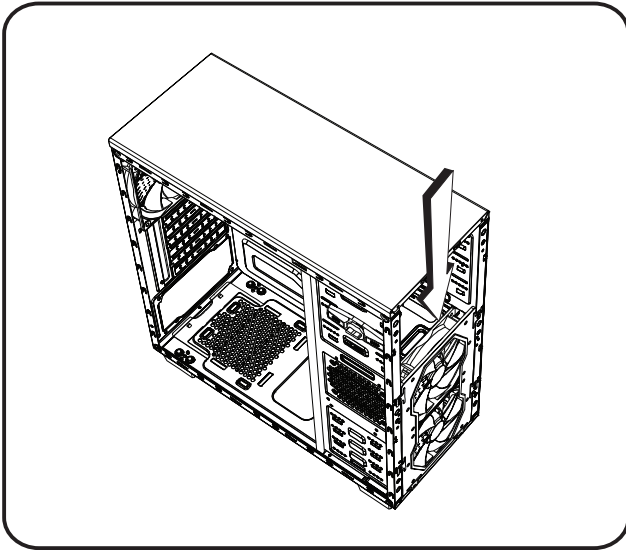

Remove the front panel and Install up to two 120mm fan(s).

Back Fan Installation

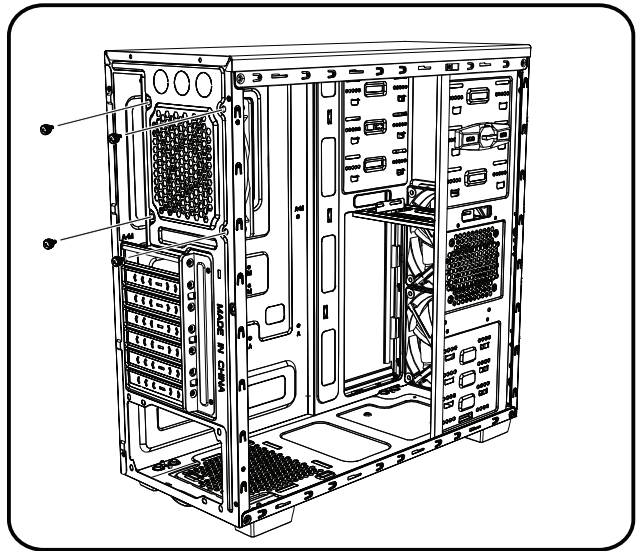
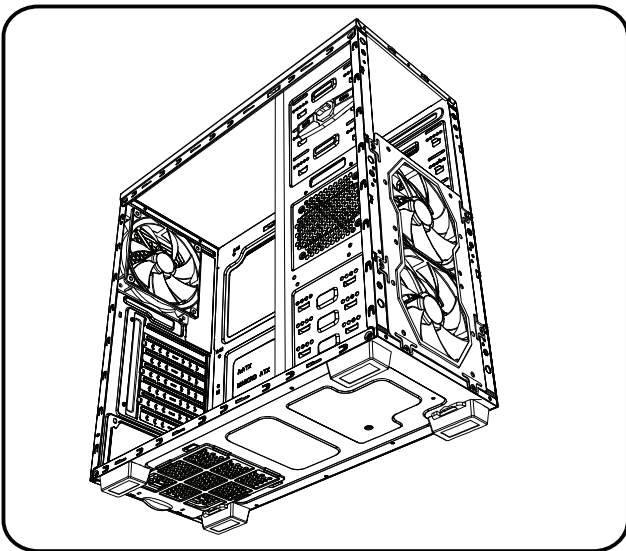

Install up to two 120mm fan.

PSU/PSU Cover Installation

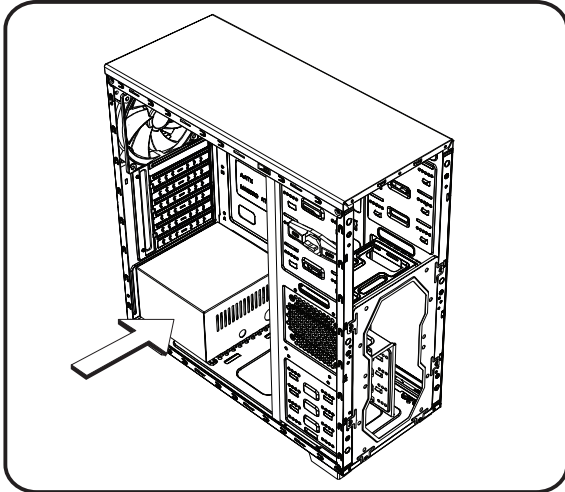

a. Push the PSU cover up and slide it to the right.

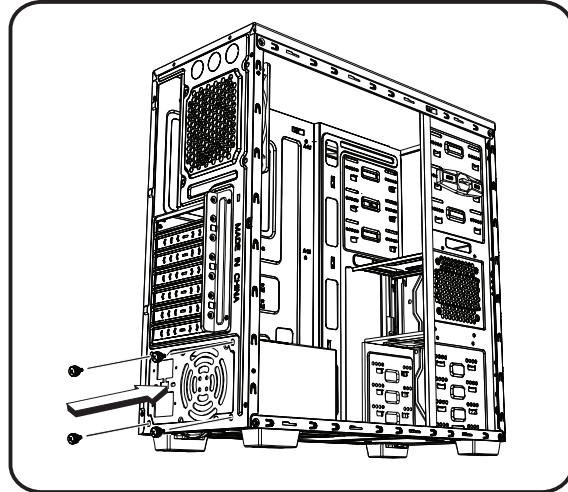

b. Insert your PSU and secure it with the PSU screws(6.32-Hex).

Installing 5.25" drives

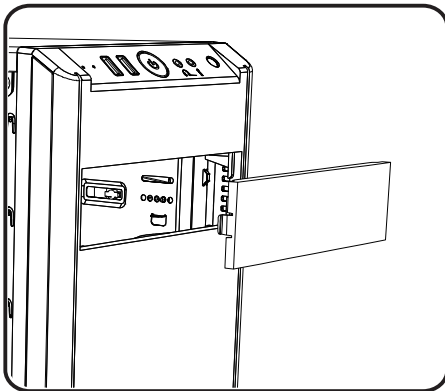

a. Remove drive cover

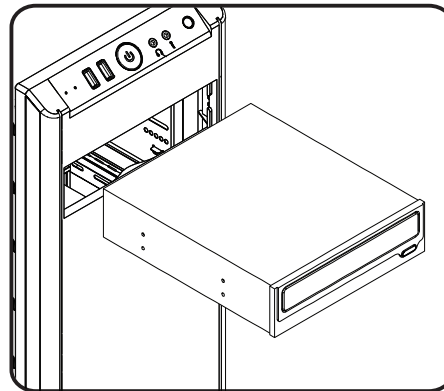

b. Slide drive into drive bay

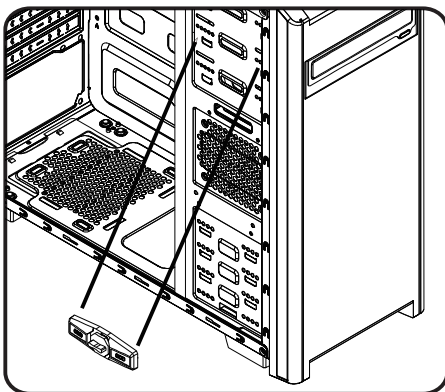

c. Squeeze and pull drive-locking mechanism

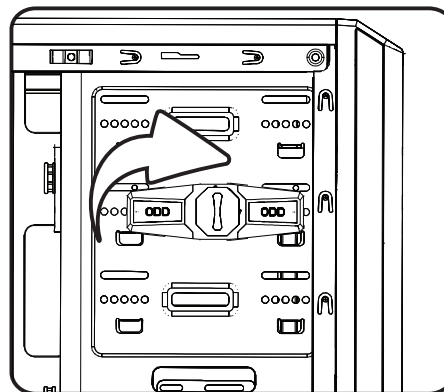

Control Panel

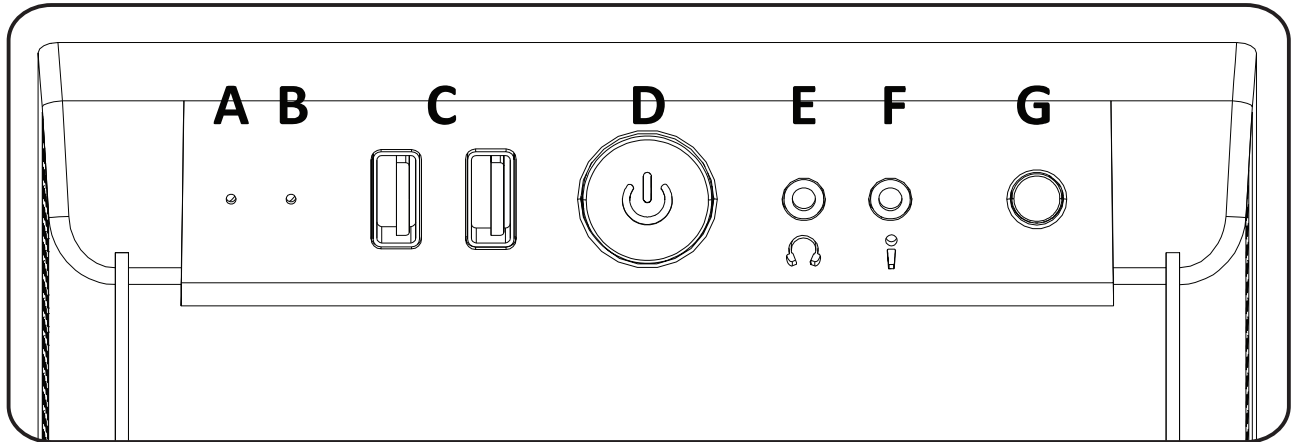

A. HDD LED(red)

B. Power LED(white)

C. USB 2.0x1 / USB 3.0x1

D. Power Button

E. Headphone jack

F. Microphone jack

G. Reset Button



BITFENIX

BitFenix Co., Ltd.

3F, No.79, Sec. 1, Xintai 5th Rd.,

Xi Zhi District, New Taipei City, Taiwan, R.O.C.

For the most updated information, please visit our official website: <http://www.bitfenix.com>

© 2015 BITFENIX Co., Ltd. All Rights Reserved. All trademarks are registered to their respective owners.

Ver 1.0 : 2015/01

* Contents and Specification are subject to change without notice



BE INVINCIBLE

WWW.BITFENIX.COM